

ELEVATION

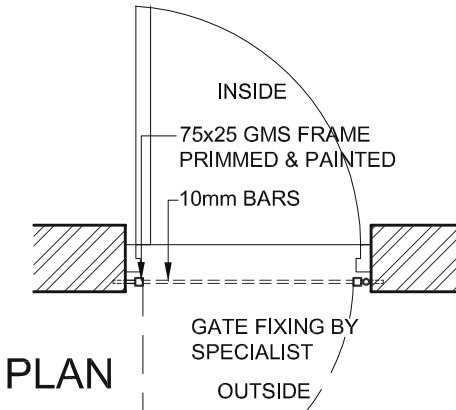

PLAN

- * DOOR NO. : D01
- * BURGULAR GUARD REFERENCE NO. : BG10
- * COLOUR : EARTH (VEDOC VP 6115)

● revisions	date	amendments
-	-	-

NOTE:
 -ALL DIMENSIONS TO BE CHECED ON SITE
 PRIOR TO INSTALLATION
 -WINDOWS VIEWED FROM THE EXTERIOR.

● drawing
 Annexure A: Entrance Gate
 - all work to be done in accordance with the sabs 0400
 - figured dimensions to be taken in preference to scaled dimensions
 - report any discrepancies direct to the architect before commencing work
 - this drawing is copyright and remains with the architect

● project WESTWOOD ESTATE NEW RESIDENTIAL APARTMENTS - PHASE 1
 ● location PROPOSED PORTION 100, ERF 3 GARDEN PARK.
 ● client SPENCER GORE DEVELOPMENTS (PTY) LTD



● scale 1:25
 ● date 17 July 2007
 ● drawn D.R

● drawing no 06030 P1 ws210

● revision
 -

tel +27 31 275 5800
 fax +27 31 275 5855
 e-mail info@eparch.co.za
 po box 2757 westway office park
 16 the boulevard westway office park
 westville - south africa